

Owners Manual Loudspeakers

DYNAUDIO

Introduction	03
Safety Instructions	05
About this guide	05
Used expressions and symbols	05
Connecting	06
Connecting the loudspeakers	06
Bi-wiring/bi-amping	07
Choice of loudspeaker cable	07
Connecting surround speakers	07
Positioning	08
General recommendations	08
Distance to back and side walls	09
Adapting the bass reflex port	09
Floor-standing loudspeaker set-up	10
Compact loudspeaker set-up	10
Loudspeaker Toe-In	11
Room and furniture influence	11
Grille	11
Multi-Channel Setup	12
Loudspeakers for multi-channel setups	12
Center Speaker	12
Rear Speakers	13
Subwoofer	13
Multi-channel loudspeaker setup	13
Running-in / Care & Maintenance	14
Warranty	15

Dear Music Lover,

Thank you for your decision to acquire Dynaudio loudspeakers.

Every Dynaudio model features the advanced Dynaudio loudspeaker technology, resulting in music reproduction at a very high level, making many familiar recordings a new listening experience altogether. This advanced technology results from many years of intense research and development, the highest quality standards in production, and Dynaudio's enduring passion for musical truth.

Dynaudio is one of very few companies who can realize such loudspeaker concepts through its own in-house development and production facilities. These facilities are so advanced and the quality control is so strict that Dynaudio is TS16949 certified.

Each loudspeaker is constructed by Dynaudio's master craftsmen in Denmark to these high standards of quality. To realize the highest sound quality from the loudspeakers, some areas should be addressed, as will be explored on the following pages.

By considering the tips and suggestions, you will achieve the maximum performance and enjoyment of the loudspeaker and its advanced musical capabilities for a long time to come.

We wish you many years of enjoyment experiencing music,
Dynaudio

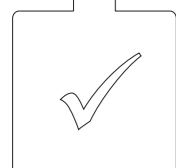
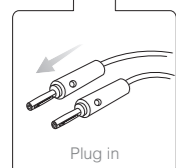
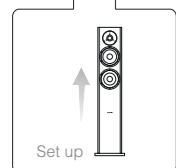
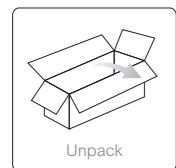

The initial set-up of a Dynaudio loudspeaker is relatively easy. Please take your time reading the guidelines and more detailed instructions on the following pages of this manual after completing the first four steps as listed below.

- 1. Unpacking.** Carefully remove the loudspeaker from the packaging and position it with its underside on the floor. Remove the white cloth cover around the loudspeaker. We suggest that you keep the box and white cloth for future use.
- 2. Positioning.** Place the loudspeaker facing the listening area at its desired position in the room. Remove the foam plugs from the rear bass reflex port (if provided with your loudspeaker model).
- 3. Connecting.** While the amplifier is switched off, connect each loudspeaker to the amplifier with the speaker cable. Turn the volume level all the way down and power the amplifier on.
- 4. Listening.** The loudspeaker is now ready to play. Optimal performance will only be realized after careful positioning and running-in the speakers as described over the course of the following pages. Enjoy your new Dynaudio loudspeakers!

Feel free to contact the Dynaudio Customer Service department with any further questions or for additional assistance.

www.dynaudio.com/service

HIGH SOUND PRESSURE LEVELS

Listening to high sound pressure levels over a longer period of time may harm your hearing.

- ▶ To avoid auditory effect do not listen to high sound levels over a longer period of time.

CAUTION



About this guide

Used expressions and symbols

In this operating manual following signs and symbols are used:

The exclamation point within an equilateral triangle is intended to alert the user to the presence of important operating and maintenance (servicing) instructions in the literature accompanying the product.

Indicates (in combination with a safety sign) a potentially hazardous situation which, if not avoided, could result in minor or moderate injury or damage to equipment.

Additional information is provided, which is important to fully understand the loudspeaker and how to operate it.

The arrow will identify steps to be performed. Please follow the instructions carefully.

Multiple steps that should be performed consecutively are numbered. Please follow these instructions carefully.



CAUTION

Note



- 1.
- 2.
- 3.

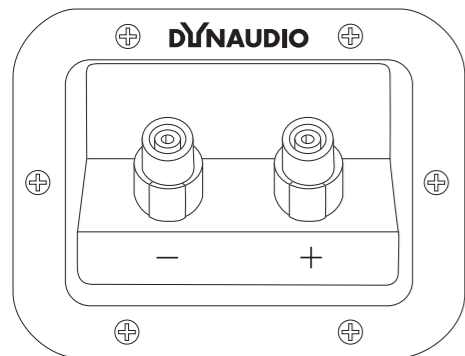

Fig. 1 Binding posts at rear of cabinet (example)

Connecting the loudspeakers

1. Connect a two-pole (+/-) loudspeaker cable to the binding posts, located at rear of the cabinet (see Fig. 1). The high quality, gold plated binding posts can accommodate different connection systems:
 - 4.0 mm banana plugs: The pins can be put directly into the binding post without any tightening necessary.
 - Cable spades: Un-tighten the binding posts, insert the spade into the opening, and secure the spade by tightening the posts.
 - Bare wires: Un-tighten the binding posts and place the cable into the binding posts. Tighten the posts.

Note

- With every connection system, ensure that the contact is tight and has a proper contact area.
- Connectors with similar gold plating as binding posts will typically offer the best results and remain corrosion-free.
- Please ensure that the positive and negative cables do not make contact with each other. Tighten the posts, and check the contact after a few days to make sure that it hasn't loosened.

2. Connect the other cable ends to the loudspeaker outputs of your switched off power amp (see Fig. 2).

Note

Please make sure that the red marked post of the speaker is connected to the red marked output of the amp, and the white or black marked post to the white or black marked output accordingly.

Bi-wiring/bi-amping

Dynaudio loudspeakers feature a carefully fine-tuned cross-over, optimized using selected parts and an advanced circuitry to achieve a truly balanced and smooth frequency response. Therefore, dividing the frequency sections through bi-wiring or bi-amping is neither beneficial nor optional.

Choice of loudspeaker cable

The loudspeaker cable can have an impact on sound quality. In general, quality cable products will yield a quality result.

Dynaudio loudspeakers are designed to be very neutral and thus are not extremely suited to any particular type of cable. The choice of cable is as much a factor of matching the cable to the entire audio system. Please consult your Dynaudio dealer for information about compatible loudspeaker cables that will suit both your electronics and your Dynaudio loudspeakers.

Connecting surround speakers

When connecting a two-channel stereo system, only the right and left channels are connected to the amplifier. In a surround set-up, center, side or rear loudspeakers as well as a subwoofer are typically connected to provide for a multi-channel listening experience. Please refer to the amplifier's owner manual for particular connection instructions and see chapter "Multichannel loudspeaker setup" on page 10 for further help.

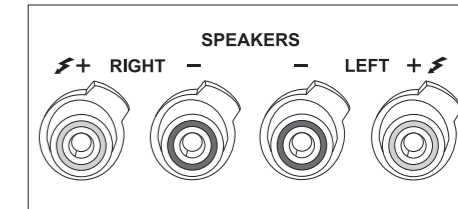

Fig. 2 Amplifier loudspeaker outputs (example)

CAUTION**EXCESSIVE BRIGHTNESS**

Direct sunlight or excessive brightness can affect the color of any natural wood veneer (the structural integrity of the cabinet will not be affected).

- ▶ To maintain the aesthetic quality of the loudspeakers for the long term, placing such in very warm, very cold, or very humid environments should be avoided.

Dynaudio loudspeakers consist of classic bass reflex loudspeaker designs with no unusual or extraordinary positioning demands. Every room will still have its own particular sound characteristics. Any room is also shaped and decorated uniquely, and therefore remains independent regarding options for positioning loudspeakers. The following steps are general suggestions that will make the correct positioning easier to achieve.

General recommendations

Following explanations refer to Fig. 3:

- The distance between each loudspeaker and your listening position should be the same (**B**). Try to achieve an isosceles triangle.
- The distance between the loudspeakers should be the same or better slightly less than the distance between each loudspeakers and your listening position (**A**, **B**).
- The closer the listening position is in relation to the loudspeakers, the closer the speakers can be positioned to each other.
- As a starting point, it is recommended that the speakers be about 2 meters apart from each other for the best results (**A**).
- If the speakers are positioned too close to each other, the stereo image will not seem realistic; if that distance is too wide, the image may leave an acoustic hole in the middle.
- Paying attention to the image during listening tests will help dictate optimum placement during experimentation and set-up.

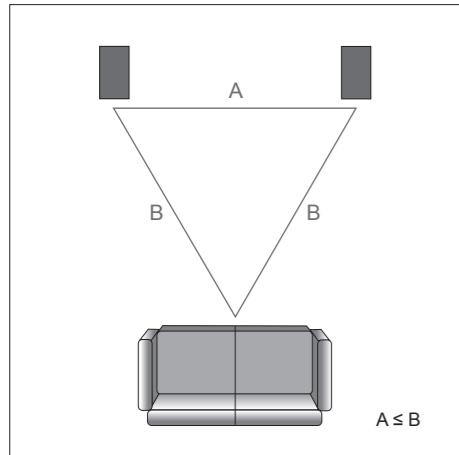

Fig. 3 Positioning the loudspeakers

Distance to back and side walls

Every loudspeaker not only disperses sound energy directly into the room, but also to the side and even backwards. As a result, time-delayed reflections occur and add to the original music signal. Thus, when loudspeakers are positioned too close to walls, the sound quality can be restricted.

Dynaudio loudspeakers were developed to be placed free-standing, and therefore they reach their optimum performance when positioned as clear of any walls as possible.

- ▶ To minimize potential influences from the back and side wall boundaries, it is recommended that the distance from the speakers to each is at least 0.5 meters, and ideally the distance from each speaker to the back and side wall should not be equal.

Adapting the bass reflex port

To minimize low frequency reflections, which will be heard as a thickening of the sound, the loudspeaker models can be adapted to the room's acoustic character by using foam plugs in the bass reflex port. This will essentially attenuate the room-induced boost in the low frequency range by dampening the deep frequencies, yielding a more clear and tight sound when the loudspeaker is positioned near rear walls.

- ▶ Fully insert the foam port plugs packed with your loudspeaker into the bass reflex tube, to attenuate the bass output (if required).

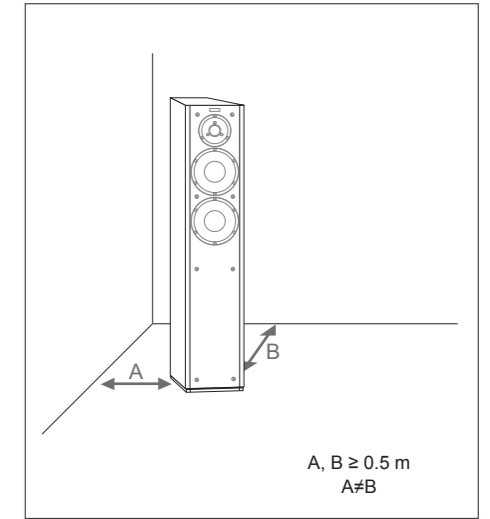

Fig. 4 Distance to walls

CAUTION**Floor-standing loudspeaker set-up**

The floor-standing models feature a special base construction, which offers both an ideal performance and mechanical basis. Integrated into the base plinth are four individual spike assemblies. These stabilize the cabinet on an extremely small contact area, and therefore prevent any wobbling while offering optimal resonance control. The individually adjustable spikes allow leveling of the cabinet on uneven floors.

SPIKES WITH SHARP PEAKS

The sharp peaks of the spikes may cause injuries and damage sensitive surfaces like hardwood flooring or tile.

- ▶ Be careful when handling the loudspeakers.
- ▶ Place plates between the spikes and the surface to protect the underlying surface.

Compact loudspeaker set-up

The compact models are designed to offer exceptional performance while taking up minimal space. The mini-monitors will realize their optimum performance when used in conjunction with a dedicated stand (such as the Dynaudio Stands) to position them at the proper height while absorbing any resonance.

Due to its dimensions, you can also place the loudspeaker on a ledge or shelf or on top of furniture. But to avoid the possibility of any negative influence on sound quality, one should take care to utilize a stable surface offering a wide enough space in front of the loudspeakers as to not limit the sound quality and performance.

In such applications or if placing the speakers in enclosed audio/video furniture, the bass reflex port can usually be left unplugged as long as there is minimal clearance to the boundaries at the top and rear of the loudspeaker cabinet.

Loudspeaker Toe-In

Depending on your personal listening environment and room dimensions, the loudspeakers may be angled in towards the listening area to focus the sound radiation. This positioning will typically improve imaging and is especially recommended by Dynaudio (see Fig. 5).

Room and furniture influence

The sound quality of any loudspeaker is influenced by the furniture, wall materials and other objects in the listening room. For example, large rooms without much furniture and many clean, hard wall surfaces can give a bright and diffuse sound with diverse echoing frequencies. A room with thick carpet, curtains and soft furniture surfaces will give a warmer, darker and less lively sound.

Grille

A cloth grille is included and can be affixed to the cabinet to help protect the drivers from dust and any other influences. The grille is acoustically optimized, but the highest sound quality levels will be attained without any grille covers in place during listening.

- ▶ To remove the grille, gently pull the grille straight away from the front.
- ▶ To fit the grille, line up the grille matching the front baffle and gently attach the grille.

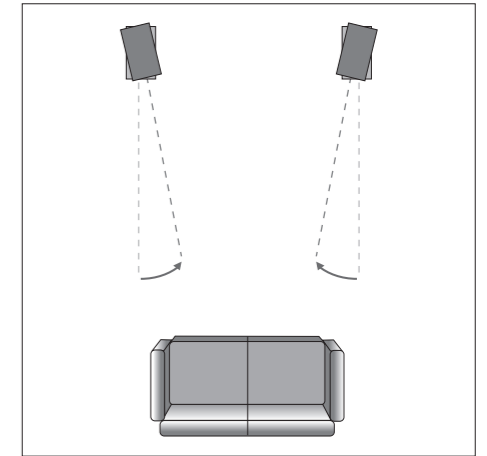

Fig. 5 Angle inwards loudspeakers to improve imaging.

Multi-Channel Setup

Dynaudio loudspeakers are designed to offer the most advanced performance in both stereo and multi-channel applications. When connecting a loudspeaker to a multi-channel setup, in general the same guidelines as mentioned in the text above will apply.

Note

When setting up a home theatre system, the loudspeakers should create a realistic soundstage with similar sound characteristics on each channel. It is therefore important that all speakers should match the same quality level. This is especially important with regards to the center channel loudspeaker, as this is critical aspect of any multi-channel soundstage.

Dynaudio has developed various models suitable for multi-channel applications: Compact and floor standing models with a matching center channel, all optimized for use with Dynaudio active subwoofers and Dynaudio optional accessory products.

Loudspeakers for multi-channel setups

For a multi-channel setup, in addition to the two main (stereo) loudspeakers, additional channels (speakers) may be added to reproduce dialogue and surround effects. With the center channel and compact models, it is possible to achieve the same high level of performance and sound on every channel.

Center speaker

The center is responsible for the information directed from the middle of the screen and should be positioned between the right and left main loudspeakers. In a home theater/surround setup, the center supports the images and should be placed close to the screen.

Rear speakers

The rear speakers are responsible for the rear sound effects behind the listening position. When using the compact models as rear speakers, the speakers can be placed into a shelf, mounted at the rear wall or placed on a stand. This allows you a wide variety of placements, even if your listening room and furniture limit a optimal setup. Corresponding to the surround format 5.1 or 7.1, you need to install additional speakers:

1. 5.1: The standard multi-channel setup with two rear speakers.
2. 7.1: Two speakers are added on both sides between the front and rear speakers.

Subwoofer

Most often a subwoofer will be utilized for the LFE-signal, especially in larger listening rooms. The position of the subwoofer will be dependent upon the size of the room and its acoustics. Please refer to the Subwoofer manual.

Multi-channel loudspeaker setup

Thus, a complete multi-channel setup consists of following speakers:

1. Front (stereo) speakers
2. Center speaker
3. Rear speakers (as explained above)
4. Subwoofer (possible position)

Because there are many different setup options – from 5.1 to 10.2 channel applications – and the fact that loudspeaker positioning will also depend upon the room's shape, please consult your Dynaudio dealer for special applications and for placement options.

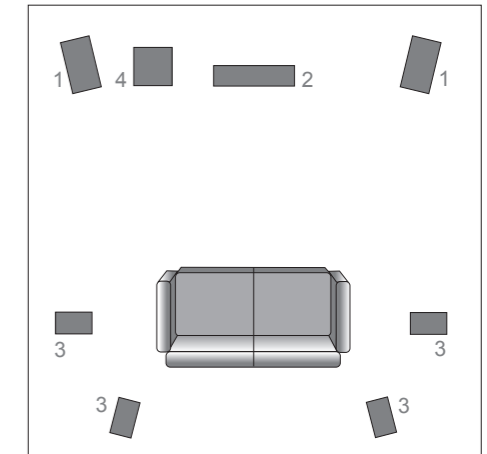

Fig. 6 5.1 and 7.1 multi-channel speaker setup.

Running-in the loudspeakers

The moving parts of a newly manufactured Dynaudio loudspeaker have been acoustically checked after production, but nevertheless are not as flexible as they need to be for optimum results to be realized. The higher the quality of any driver system, the more demanding the loudspeaker will be regarding time for running-in the system.

A newly unpacked Dynaudio loudspeaker therefore requires several weeks running/playing to reach its optimum performance capability. After that period, a couple of minutes before every listening session will be helpful to "warm up" the loudspeakers.

Power rating

Due to the construction and the driver technology Dynaudio loudspeakers can be driven with very high power levels. With a high quality amplifier, delivering undistorted signals, the speaker can achieve high levels without any compromises in sound quality. Attention must be given to amplifiers with very low power and adjustable tone controls or switches. These types may soon overreach their own performance limits and may send distorted output signals to the speakers, compromising even high quality technology. Any damage caused under such circumstances is not covered by the Dynaudio warranty and is easily avoided in the first place by consulting your Dynaudio dealer for advice regarding the choice of amplifier.

CAUTION**DISTORTED OUTPUT SIGNALS**

Distorted output signals from too weak, defective or overloaded amplifiers may damage the loudspeakers.

- ▶ Use high quality amplifiers only and run loudspeakers and amplifiers within specified power ratings.

Dynaudio loudspeakers require no special treatment apart from the kind of careful handling you would normally apply to any high tech product in your home.

AGGRESSIVE CLEANING FLUIDS

All-in-one cleaning materials, aggressive cleaning fluids or special furniture polishes may damage the cabinet surface or other speaker parts.

- ▶ Use a soft dry or slightly damp cloth when cleaning the cabinet and other plain parts.

CAUTION**Cleaning the loudspeakers:**

- ▶ Switch off all components of your system when cleaning any of these components.
- ▶ Avoid touching the tweeter domes as any change of their shape may have an impact on sound quality.
- ▶ Clean the cabinet and other plain parts with a soft dry or slightly damp cloth only.
- ▶ Remove dust on the woofer diaphragms with a fine furniture brush.

All materials used by Dynaudio are integrated with exceptional care. By taking care of your loudspeakers, you will preserve the finish and build quality for a very long time.

Dynaudio provides a transferable limited manufacturer's warranty. This warranty only covers faults or defects in material and production. Damage caused as a result of abuse, misuse or defective electronics is not covered by the warranty. All warranty claims must be accompanied by a copy of the original purchase invoice and warranties are only valid in the country or market of original origin or distribution. Should warranty service be required, it must be arranged for in the country of purchase by an authorized Dynaudio dealer. All performance criteria are strictly controlled. In the whole production procedure – from raw materials to the final assembly – Dynaudio thoroughly inspects all parameters along every step of way.

All there is.

DYNAUDIO

Dynaudio A/S, 8660 Skanderborg, Denmark
Sales & Marketing: Dynaudio International GmbH, Ohepark 2, 21224 Rosengarten, Germany, Phone: +49 4108 - 41 80 - 0
www.dynaudio.com